

VC1902-PA-VIVA1596
VC1802-PA-VIVA1596



Passive Adaptors to test power delivery network to Versal ACAP VIVA1596 series FPGA's

ProGrAnalog Corp.
04/07/2023
Rev 2.0

Features

- Set of 3 Passive Adaptors (PA) for PDN testing AMD Xilinx Versal ACAP AI VIVA1596 series FPGAs
- Options available for VC1902, VC1802.
- 6 Samtec connectors to slam: VCCINT, VCC_IO, VCC_SOC, VGTY_AVTT, VCCAUX, AVCC
- 8 SMP connectors for testing: VCCINT_SENSE, GND_SENSE, GND, VCC_IO, VCC_SOC, VGTY_AVTT, VCCAUX, AVCC
- PA with BGA footprint reflows onto VIVA1596 PCB pads.
- Remote Vsense on Samtec connectors and SMP mini connectors.
- Most rails can be tested with an LSP200 controller.
- VCCINT >100A support with an LSP1000RS controller.
- GUI supports transient, pulse train, impedance and 3D plots.

Typical Test Setup

- Passive Adaptor reflowed onto the test board.
- LSP1000RS connected into VCCINT connector.



Pack of 3 -VIVA1596 Series PA's

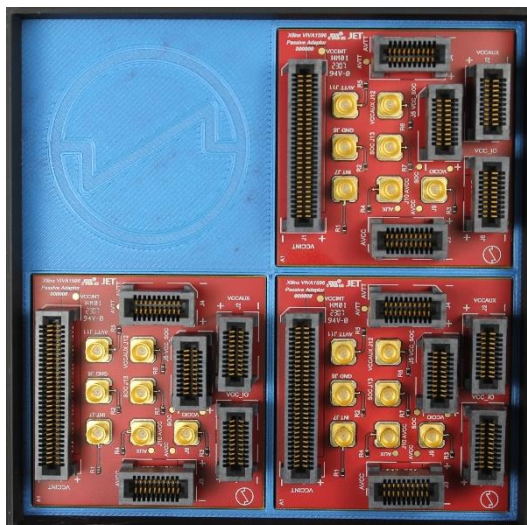

LoadSlammer GUI

Workspace **Test - 1** x

Available Tests Name: Test - 1 Rail: None

- Transient Test**
Transient load step with adjustable rise times, current, and pulse width.
- Pulse Train**
Repeating load steps with a configurable frequency and duty cycle.
- Impedance (Z)**
Large signal output impedance with adjustable current amplitude and offset.
- DC Load**
DC Load with timer.
- Delay**
Timed delay.

Transient test

Workspace **Test - 1 - Main** x



▶ Run Delete Configure

Text	Offset	Amp...	Time...	Mini...	Edge...	Index	Params	Pass	V _{droop}	V _{thoff}
▶ <input checked="" type="checkbox"/> ...	80 A	175 A	20 μ s	2.5 ms	1 μ s	1	Current: 175 A, EdgeTime: 1 μ s	✔	834.6 mV	873.6 mV
						2	Current: 175 A, EdgeTime: 1 μ s	✔	834.6 mV	874.2 mV

Type	Min	Avg	Max	Std Dev	PassRate



Mechanical Specs

View from Top side (Scale 3:1)

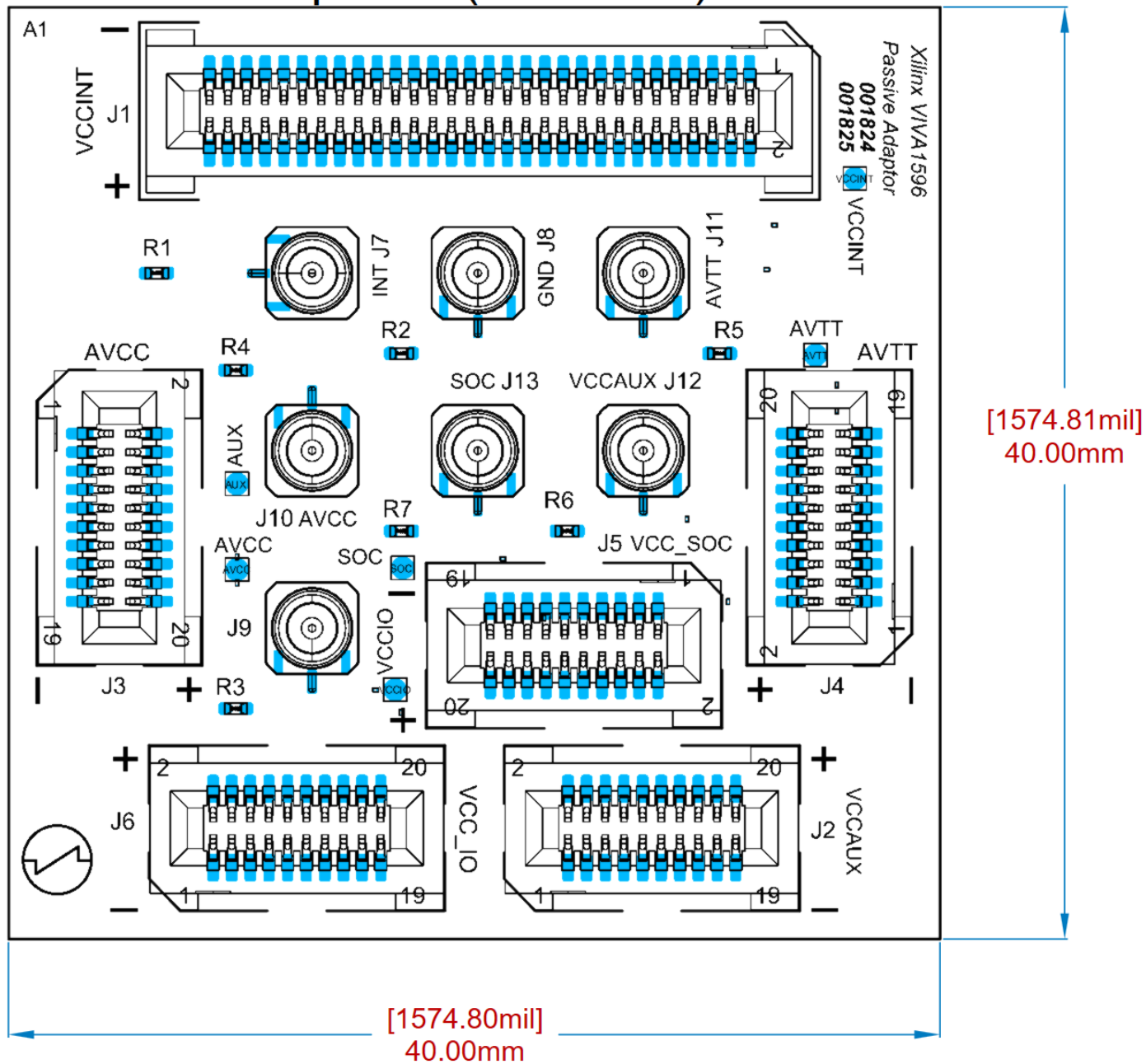

View from Bottom side (Scale 3:1)

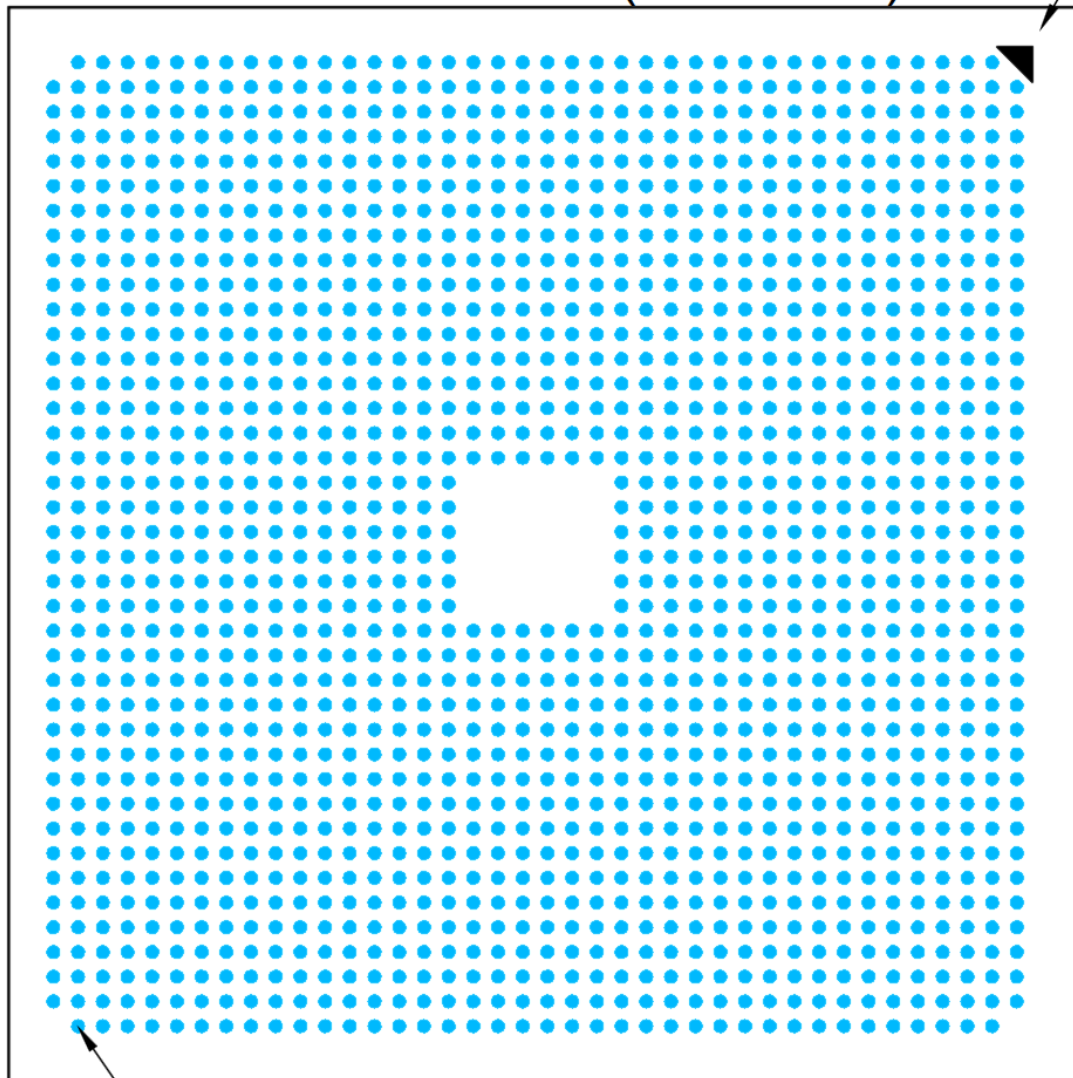

Pin 1 I.D.

0.92mm BGA Pitch

Sn96.5-Ag3.0-Cu0.5 0.5mm balls

Packing Tray Specs

40x40mm package will have a 92x92x15mm tray

A1 top left corner

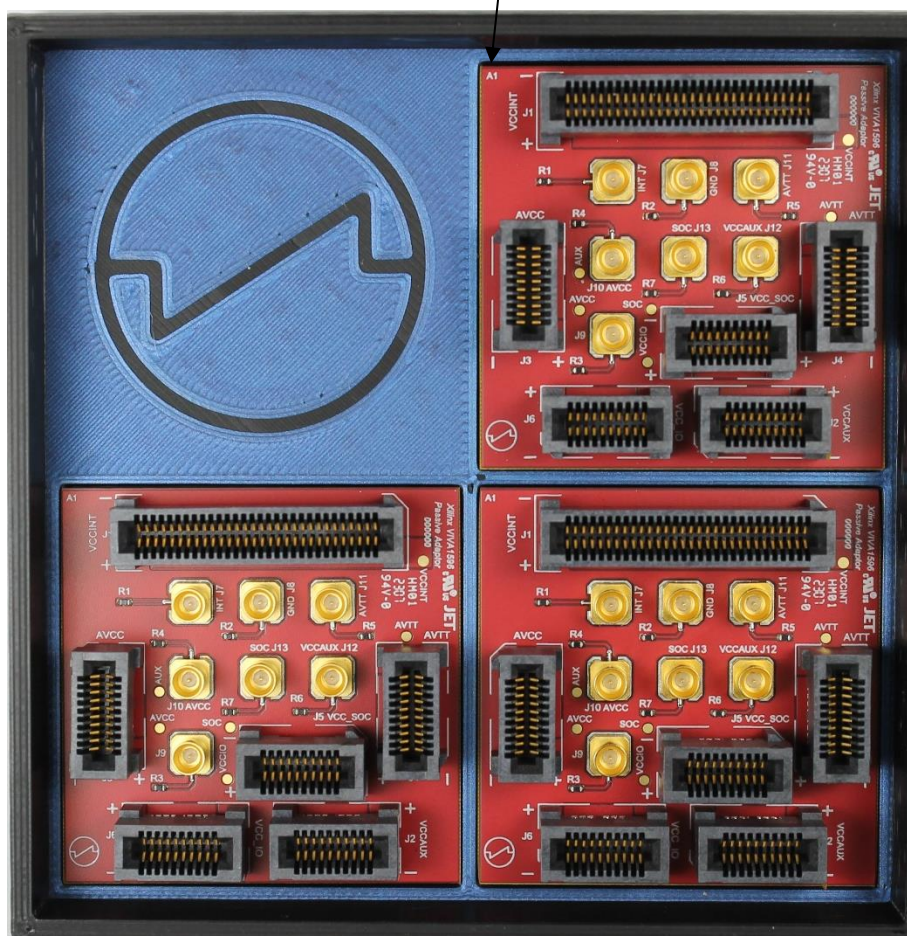

Schematics

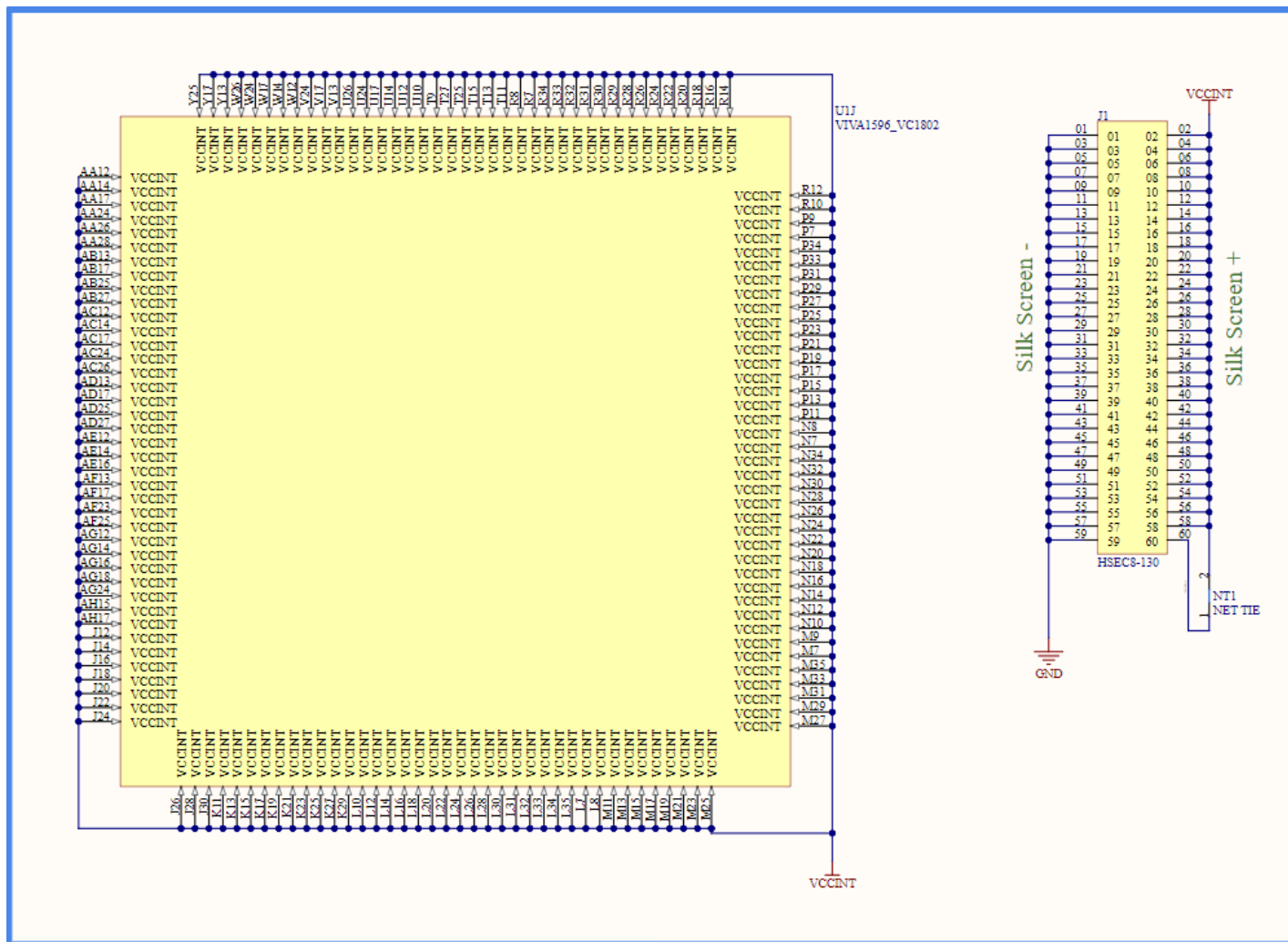

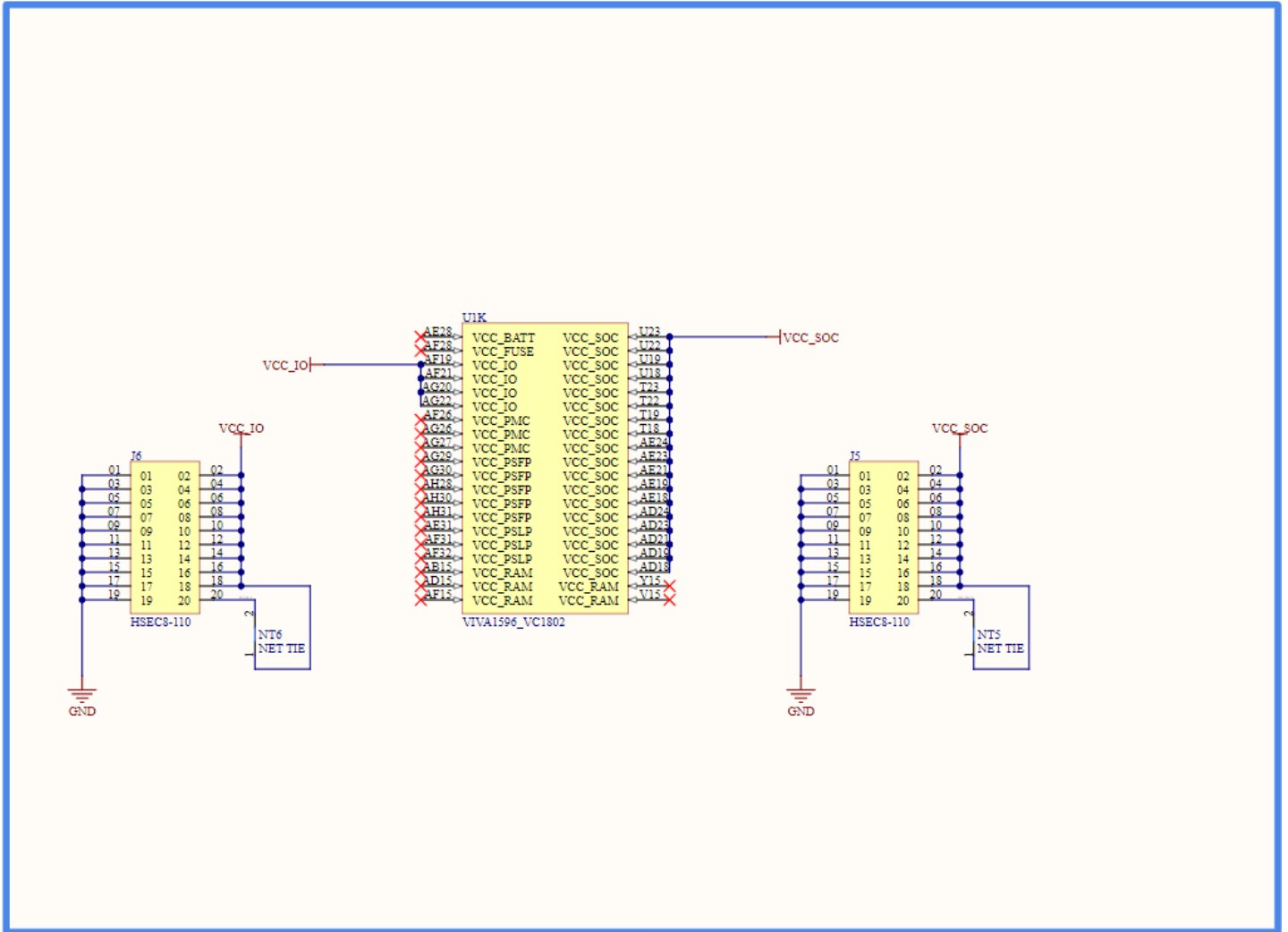

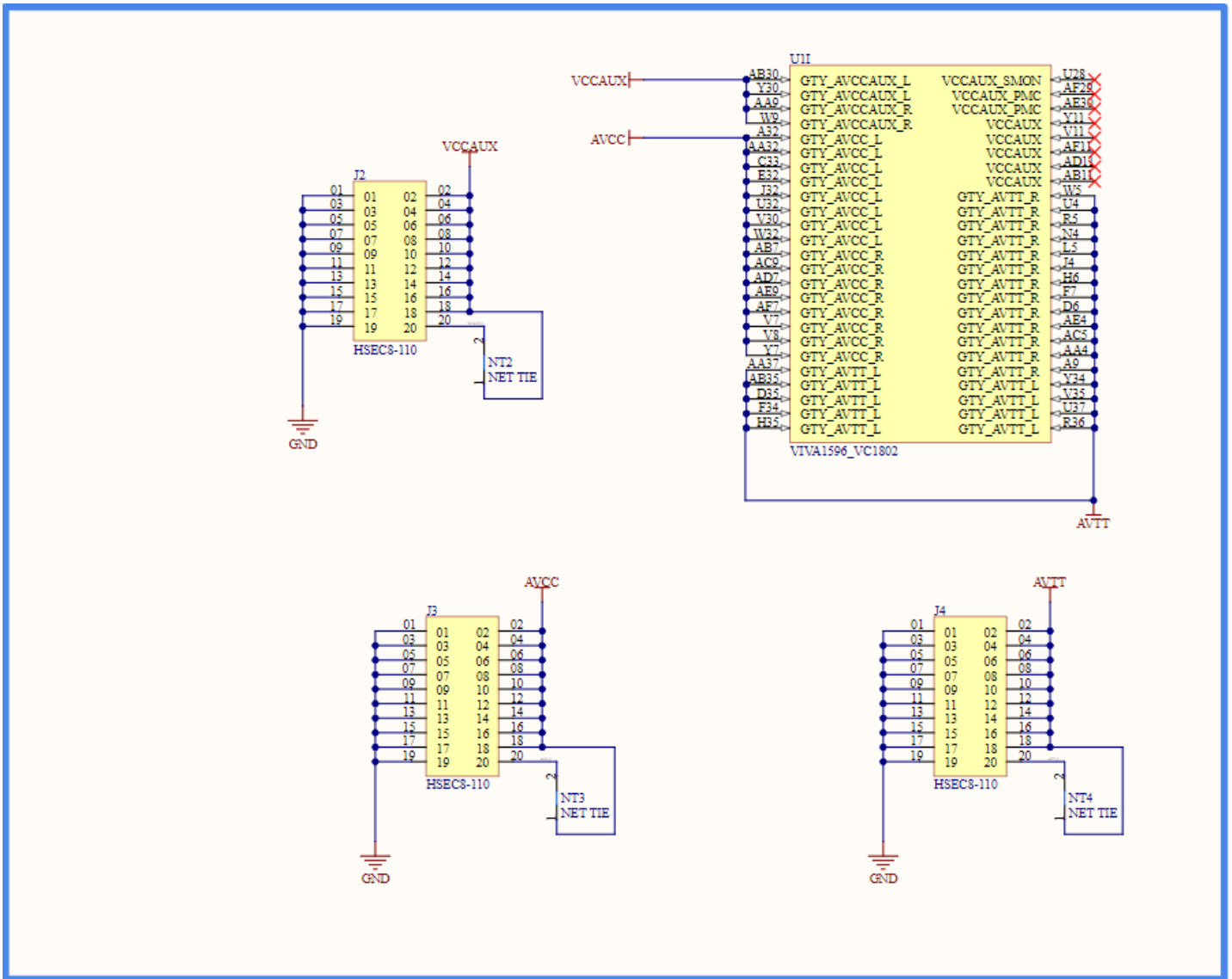

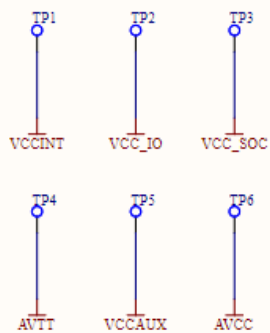

TEST POINTS

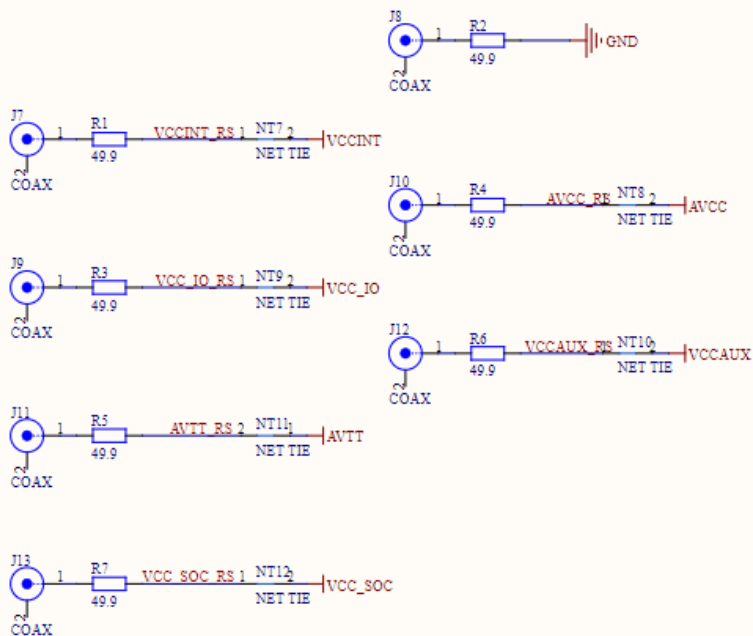

COAX SMP

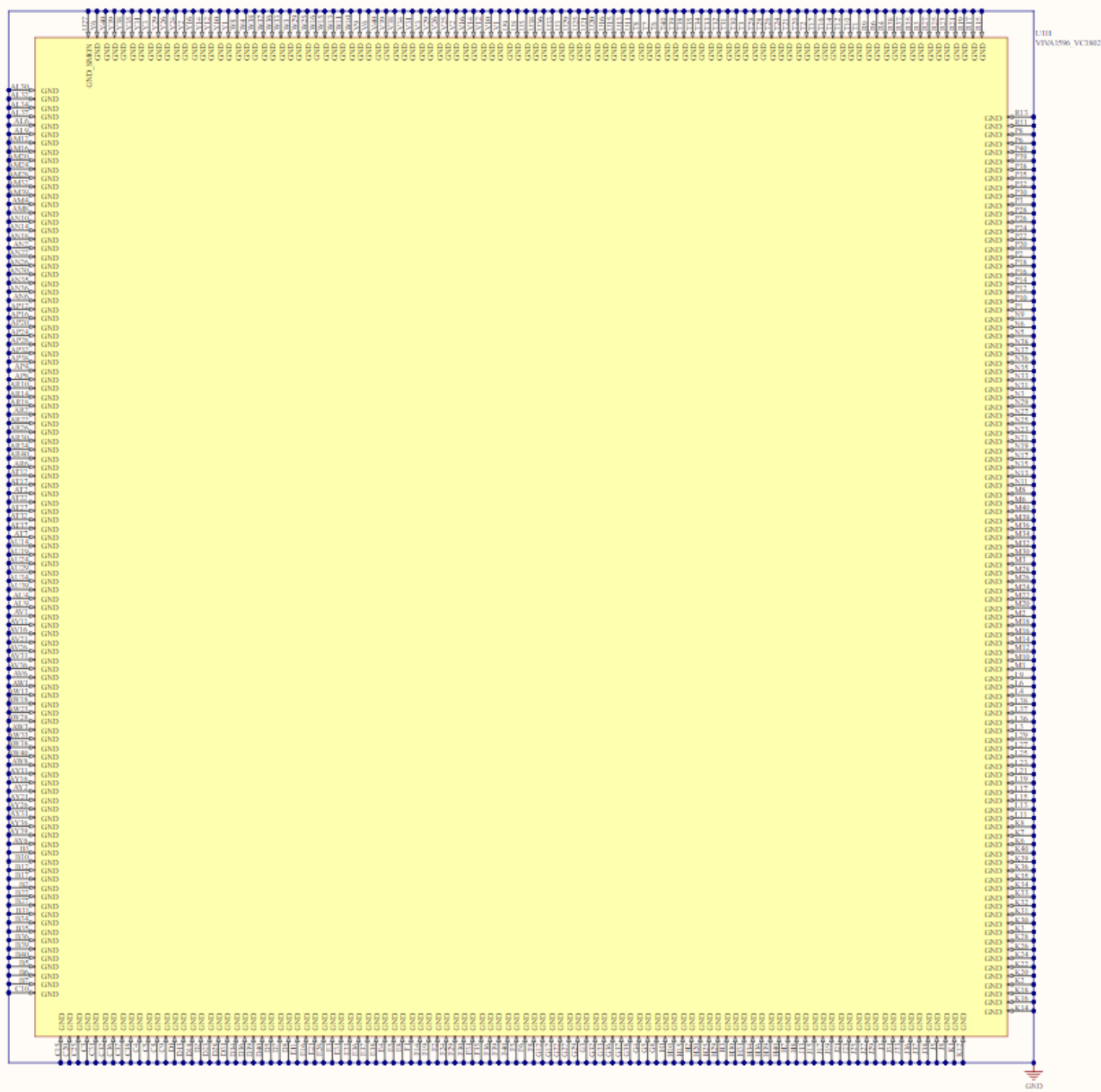

Availability

Xilinx part number	ProGrAnalog part number
VC1802-VIVA1596	PA-KIT-VC1802-VIVA1596
VC1902-VIVA1596	PA-KIT-VC1902-VIVA1596

N America:

<https://www.mouser.com>

<https://www.avnet.com>

China:

<https://www.forenext.com>

EMEA:

<https://www.avnet.com>

Taiwan:

<https://www.forenext.com>

Visit us at:

<https://loadslammer.com>

Questions:

support@progranalog.com